



Ball valves

Válvulas de bola



Certifications and tests

Pruebas y certificaciones



Firesafe test

Prueba antifuego

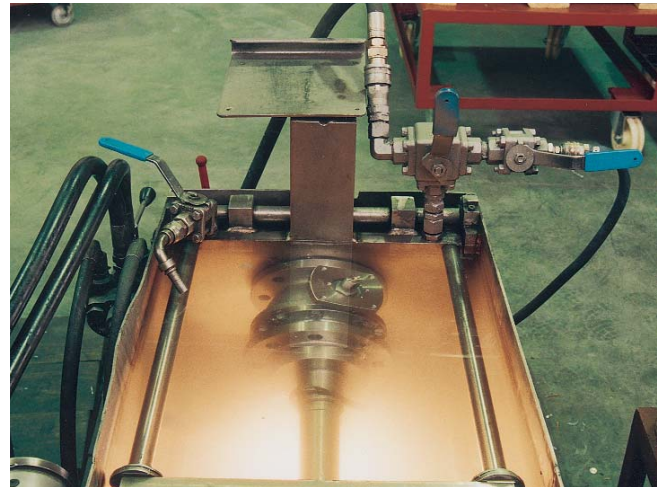

Final inspection

Inspección final

Certificates of the company / Certificados de empresa

ISO 9001	Quality Assurance System Sistema de Gestión de la Calidad
AD-Merkblatt WO/TRD 100	Manufacturing process and Quality System Procesos de fabricación y Sistema de Calidad
API Monogram	Standard API 6D . certificate number: 6D-0363 Norma API 6D . Certificado n° 6D-0363

Certificates of the product / Certificados de producto

Lloyd's Type Approval	Fire Safe & type approval Antifuego y aprobación tipo
TUV AR.263-01	Design of the valves Diseño de las válvulas
TUV AGG.268-97	Hazardous liquids transportation Transporte de líquidos peligrosos
TA-Luf	Stem tightness for gas emissions Estanqueidad del eje para emisiones de gas
CE	Pressure equipment CE marking (97/23/EC Directive) Marcado CE de los equipos a presión (Directiva 97/23/CE)
ATEX 	Conformity with Directive 94/9/EC - (II2GD) Cumplimiento de la Directiva 94/9/CE - (II2GD)
Cryogenic	Cryogenic as per norm BS 6364 Criogénica según norma BS 6364
EN 161 / EN 164	For cut off gas burners and gas equipment Para cierre de quemadores y aparatos de gas
Helium -40 °C	Leeds University test Prueba en la Universidad de Leeds
GOST-R	Russian Federation Certificate Certificado para estados federados de Rusia
Sanitary approval (Russian)	Food processing and Pharmaceutical industry Procesos alimentarios e industria farmacéutica

Approvals of companies / Homologaciones de empresas

Repsol-YPF (Spain)
Qatar Petroleum (Qatar)
Al Furat Petroleum (Syria)
Sasol Technology (South Africa)
Al-Jawaby (Libia)-U.K. London
Medoil (Libia)- Düsseldorf

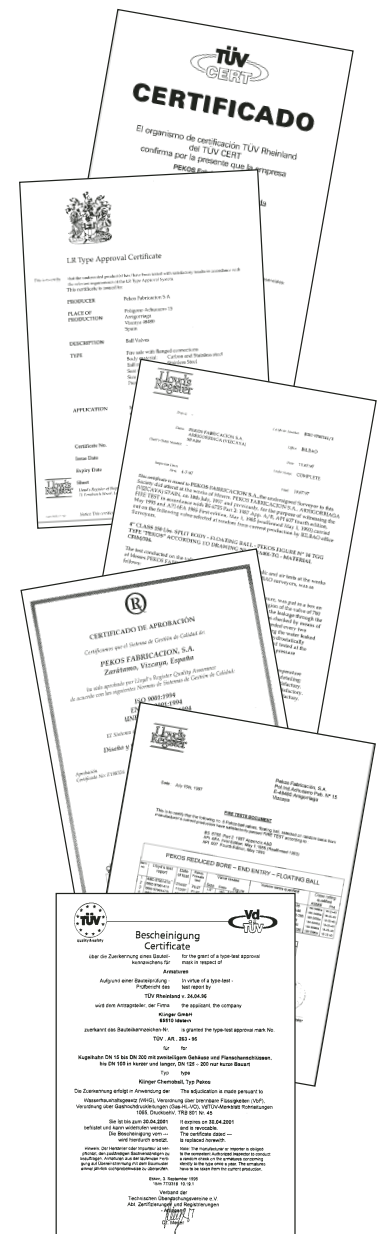

General features

- Construction "split body".
- Construction DIN 3357 PN 10 up to PN 40.
- Distance between flanges as per EN 558-1:
 - DN 15 to DN 100 basic serie 1 (equivalent to DIN 3202 F1)
 - DN 15 DN to 100 basic serie 14 and 27 (equivalent to DIN 3202 F4)
 - DN 125 a DN 400 basic serie 15 and 27 (equivalent to DIN 3202 F5)
- Flanges drilled as per EN-1092 PN10-40 and DIN 2532, 2533, 2542, 2543, 2544, 2545 and ISO 7005.
- Flanges surfaces as per EN 1092 type B and DIN 2526 form C.
- Leak test as per EN 12266 and DIN 3230 parte 3.
- Top flange ISO 5211 for actuator assembly.
- Standard construction materials are: cast iron, carbon steel and stainless steel. Special alloys can be supplied upon request.

Características generales

- Construcción del cuerpo en dos piezas.
- Construcción según DIN 3357 de PN10 a PN40.
- Distancia entre bridas según norma EN 558-1:
 - DN 15 a DN 100 serie básica 1 (equivalente a DIN 3202 F1)
 - DN 15 a DN 100 series básicas 14 y 27 (equivalente a DIN 3202 F4)
 - DN 125 a DN 400 series básicas 15 y 27 (equivalente a DIN 3202 F5)
- Taladrado de las bridas según normas: EN 1092 (PN10-40) y DIN 2532, 2533, 2542, 2543, 2544 y 2545 e ISO 7005.
- Superficie de las bridas según EN 1092 tipo B y DIN 2526 forma C.
- Pruebas de estanqueidad según EN 12266 y DIN 3230 parte 3.
- Brida superior según ISO 5211 para adaptación de actuadores.
- Materiales de construcción estándar: fundición de hierro, acero al carbono y acero inoxidable. Bajo demanda se pueden suministrar aleaciones especiales.

Design advantages

Ventajas del diseño

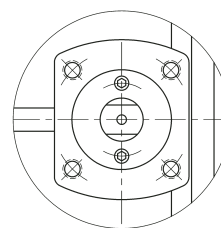
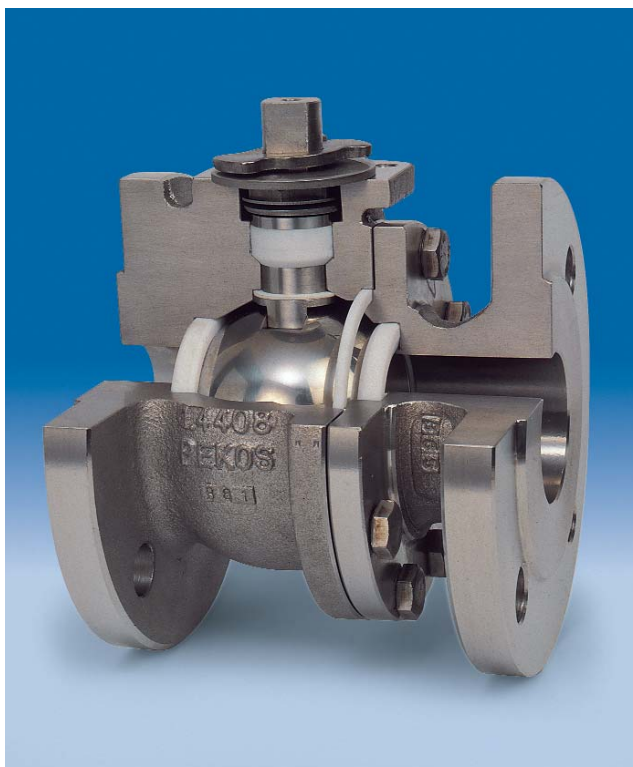

Top flange ISO 5211
Brida superior ISO 5211

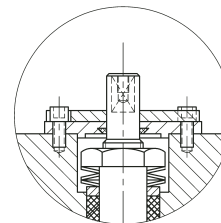

Guided stem
Eje guiado

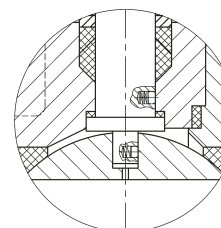

Stem packing
MAINTENANCE FREE
Estopada del eje LIBRE
DE MANTENIMIENTO

Anti-blow out stem
Eje no eyectable

Antistatic device.
Eje antiestático

Standard construction materials

Materiales de construcción estándar

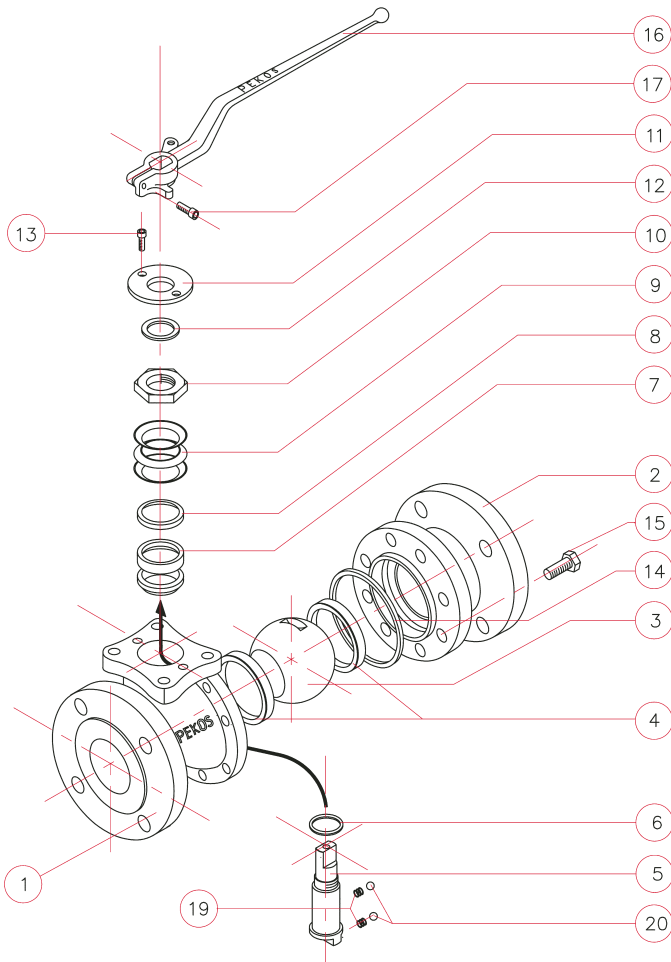

Valves from DN 15 up to DN 32

Válvulas de DN 15 a DN 32

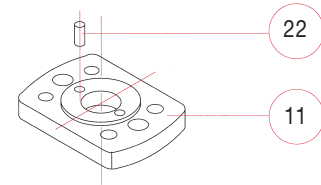

Guided ball valves DN 150-200 PN (25-40) DN 250-400

Válvulas de bola guiada DN 150-200 PN (25-40) DN 250-400

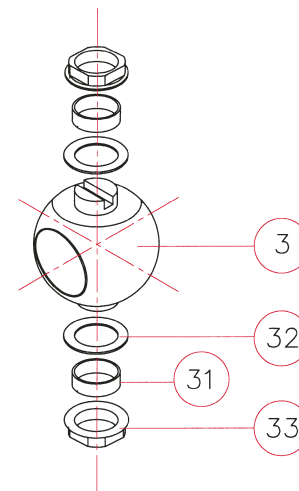

Item	Description	Descripción	Cant.	Fig. 02 TTT	Fig. 04 / 24 TTT	Fig. 06 / 26 TTT
1	Body	Cuerpo	1	GG 25 C.I.	1.0619 C.S.	1.4408 S.S.
2	Body adapter	Cuerpo lateral	1	GG 25 C.I.	1.0619 C.S.	1.4408 S.S.
3	Ball	Bola	1	1.4308 S.S.	1.4408 S.S.	1.4408 S.S.
4	Seat	Asiento	2	PTFE (T)	PTFE (T)	PTFE (T)
5	Stem	Eje	1	1.4021 S.S.	1.4401 S.S.	1.4401 S.S.
6	Stem washer	Junta eje	1	PTFE+FG (R)	PTFE+FG (R)	PTFE+FG (R)
7	Packing ring	Estopada	1	PTFE (T)	PTFE (T)	PTFE (T)
8	Gland packing	Anillo prensa	1	1.4401 S.S.	1.4401 S.S.	1.4401 S.S.
9	Spring washer	Arandela muelle	3	1.4310 S.S.	1.4310 S.S.	1.4310 S.S.
10	Stem nut	Tuerca eje	1	1.4305 S.S.	1.4305 S.S.	1.4305 S.S.
11	Cover	Tapa	1	1.4408 S.S.	1.4408 S.S.	1.4408 S.S.
12	Cover ring	Anillo tapa	1	PTFE (T)	PTFE (T)	PTFE (T)
13	Cover bolt	Tornillo tapa	2	8.8	8.8	A4 70
14	Body seal	Junta cuerpo	1	PTFE (T)	PTFE (T)	PTFE (T)
15	Body bolt	Tornillo cuerpo	-	8.8	A2-70	A4-70
16	Handle	Maneta	1	Aluminium	1.4308 S.S.	1.4308 S.S.
17	Handle bolt	Tornillo maneta	1	8.8	8.8	8.8
19	Spring	Muelle	2	--	1.4319 S.S.	1.4319 S.S.
20	Ball	Bola	2	--	1.4401 S.S.	1.4401 S.S.
22	Stop pin	Pasador tope	2	--	1.4401 S.S.	1.4401 S.S.
31	Bearing	Cojinete	2	--	PTFE (T)	PTFE (T)
32	Bearing disk	Cojinete axial	2	--	PTFE+FG (R)	PTFE+FG (R)
33	Support bearing	Soporte cojinete	2	--	1.4401 S.S.	1.4401 S.S.

Dimensions and weights

Dimensiones y pesos

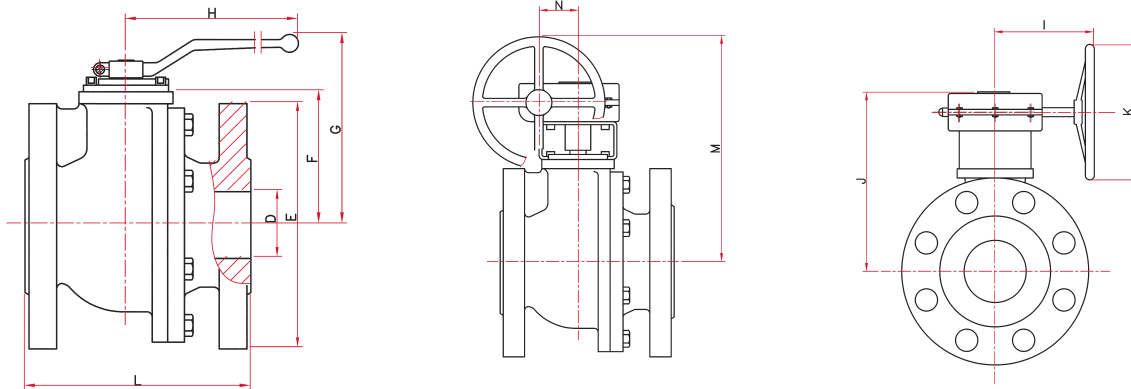

DN	D	L			E		F	G	H	I	J	K	M	N	Weight / Peso*		
		F1 (1)	F4 (2)	F5 (3)	PN 16	PN 40									F1	F4	F5
15	15	130	115		95	95	52	100	185						3	3	
20	20	150	120		105	105	54	102	185						4	3	
25	25	160	125		115	115	60	110	185						5	4	
32	32	180	130		140	140	65	115	185						7	6	
40	40	200	140		150	150	75	129	293	170	203	300	310	60	9 / 13	8 / 12	
50	50	230	150		165	165	83	137	293	170	210	300	318	60	12 / 16	11 / 15	
65	65	290	170		185	185	96	150	293	170	223	300	330	60	19 / 23	15 / 18	
80	80	310	180		200	200	114	187	350	170	261	300	379	60	26 / 30	20 / 23	
100	100	350	190		220	235	128	201	350	170	286	300	393	60	33 / 37	29 / 32	
125	125			325	250	270	158	247	680	210	328	400	472	70			58 / 64
150	150			350	285	300	175	264	680	210	345	400	482	70			75 / 82
200	200			400	340	375	245	334	750	272	435	500	635	100			137 / 165
250	250			450	405	450	285	-	-	272	475	500	675	100			220 / 248
300	300			500	460	515	336	-	-	272	526	600	808	100			290 / 318
350	350			550	520	580	347	-	-	300	595	600	820	138			377 / 407
400	400			600	525	585	386	-	-	300	634	600	920	138			480 / 510

* When two values are indicated, the highest one corresponds to the valve with gear box. * Cuando se indican dos valores, el mayor corresponde a la válvula con reductor.
 (1) EN 558-1 serie 1 (2) EN 558-2 serie 14 or 27 (3) EN 558-2 serie 15 or 27

Top flange ISO 5211

Brida superior ISO 5211

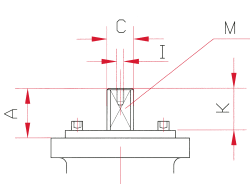

DN	15	20	25	32	40	50	65	80	100	125	150	200	250	300	350	400
ISO 5211	F05	F05	F05	F05	F07	F07	F07	F10	F10	F12	F12	F14	F14	F14	F16	F25
M (e/c)	8	8	10	10	14	14	14	19	19	26	26	32	32	32	46	55
C (ø)	12	12	16	16	20	20	20	25	25	34	34	42	42	42	60	72
A	16	16	22	22	25	25	25	27	27	38	38	43	43	43	63	73
K	13	13	19	19	22	22	22	24	24	35	35	40	40	40	60	70
I	M4	M4	M4	M4	M6	M6	M6	M8	M8	M8	M8	M8	M8	M8	M8	M8

Stem extensions

Extensiones del eje

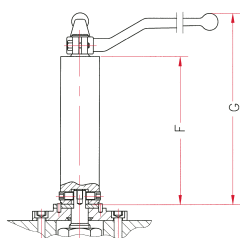

Simple stem extension (DN 15 up to DN 100)
 Alargamiento simple (DN 15 a DN 100)

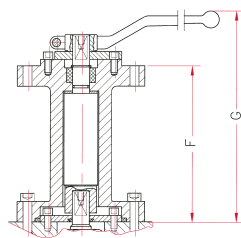

Standard extension
 Alargamiento estándar

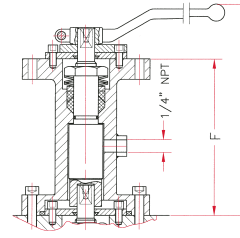

Security and fugitive emission detector
 Seguridad y detector de fugas

DN	15	20	25	32	40	50	65	80	100	125	150	200	250	300	350	400
F	150	150	150	150	150	150	150	150	150	150	150	150	150	150	150	150
G	204	204	204	204	204	204	204	225	225	239	239	-	-	-	-	-

Technical features / Características técnicas

Breakaway torques

Pares de apertura

DN	15	20	25	32	40	50	65	80	100	125	150	200	250	300	350	400
N.m	8	10	14	23	31	46	55	85	110	240	380	540	950	1200	2130	2860

- Tests performed with clean water at ambient temperature, PTFE (T) seats Δp 16 bars.
- With S or R seats type and with certain fluids, the above torque values should be increased by 30% to 50%.
- Breakaway torque could rise by up to 50% after long idle time, but goes down to normal after the first few cycles.
- Many factors can influence the breakaway torque such as: low or high temperature, dry gas, stem detergent, water, demineralized water, slurry dirty, abrasive content, etc...

- Pruebas realizadas con agua limpia a temperatura ambiente, asientos de PTFE (T) a Δp de 16 bares.
- Para los asientos de tipo S o R y en función del tipo de fluido, estos valores pueden incrementarse entre un 30% y un 50%.
- El par de arranque puede aumentar hasta un 50% después de un tiempo de inactividad, luego se va suavizando al maniobrarlo.
- Muchos factores influyen en el par de maniobra: baja o alta temperatura, gas seco, vapor, agua, agua desmineralizada, salmuera, suciedad, abrasividad del producto, etc...

Kv values

Valores de Kv

DN	15	20	25	32	40	50	65	80	100	125	150	200	250	300	350	400
Kv (m ³ /h)	18	38	60	105	170	255	480	910	1500	2450	3900	8400	13800	18300	23500	32100

Leak tests

Test specifications according DIN 3230 part 3 and EN 12266.

Pruebas de estanqueidad

Especificaciones de prueba según DIN 3230 parte 3 y EN 12266.

	Hydraulic shell test Prueba hidráulica del cuerpo	Hydraulic seat test Prueba hidráulica del cierre	Pneumatic seat test Prueba neumática del cierre
PN 10	15 bar	11 bar	6 bar
PN 16	24 bar	18 bar	6 bar
PN 40	60 bar	44 bar	6 bar

Tests duration / Duración de las pruebas	
Size / DN	Time / Tiempo
15-40	0.25 min
50-150	1 min
200	2 min
250-400	3 min

Pressure-temperature graph / Gráfico presión temperatura

Line / Línea	Size / Tamaño
1	DN15 up to DN 20
2	DN 25 up to DN 65
3	DN 80 up to DN 100
4	DN 125 up to DN 150
5	DN 200 up to DN 400

— Blue/Azul	Body Cuerpo
— Green/Verde	Seats in PTFE+25% FG Asiento en PTFE+25% FV
— Red/Rojo	Seats in PTFE Asiento en PTFE

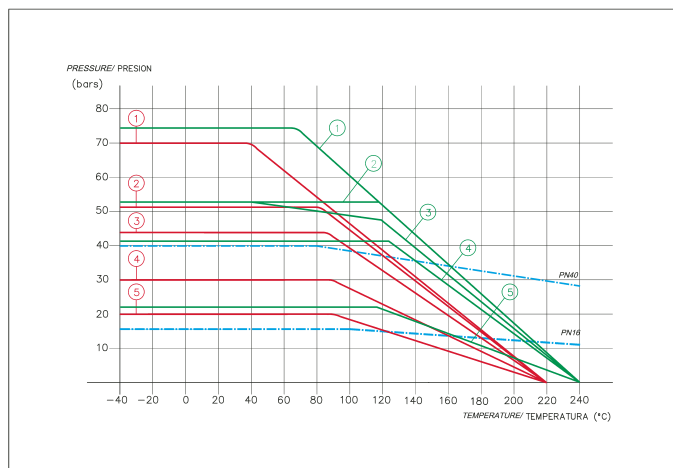

Brackets / Torretas

ISO 5211	E	F
F05F05	80	50
F07F05	80	50
F07F07	80	50
F10F07	140	80
F10F10	140	80
F12F10	140	80
F12F12	140	80
F14F12	160	90
F14F14	160	90
F16F14	220	120
F25F16	320	180

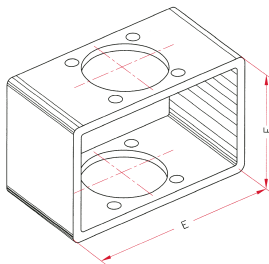

Adaptors / Acoplamientos

As per DIN 3357 / Según DIN 3357

Nº	DN	L1	L	EC
00	15-20	12	41	11
01		15	56	14
11	25-32	15	53	14
12		18	56	17
22	40-50-65	18	56	17
23L		23	91	22
33		23	91	22
34	80-100	28	96	27
44		28	92	27
46	125-150	37	111	36
56		37	111	36
57	200-250-300	48	152	46
67		48	82	46
68	350-400	57	162	55

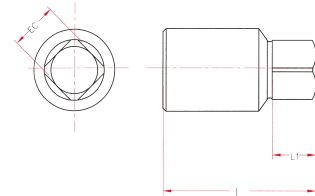

How to order PEKOS ball valves / Cómo pedir las válvulas de bola PEKOS

Special prefix Prefijo especial	I Class Clase	II Base materials Materiales base	III Seats Asientos	IV Stem packing Estopada	V Body seal 1 Junta cuerpo 1	VI Body seal 2 Junta cuerpo 2	VII Stem O-ring Junta tórica eje
B Sampler Toma muestras	0 F-4 / F-5	0 Special Especial	T PTFE	T PTFE	T PTFE	G Graphite Grafito	V Vitor® (FKM)
C Cavity filler Cámara muerta	1 150 Lbs	1 GG25 / 1.4408	R PTFE + Fibreglass PTFE + Fibra vidrio	R PTFE + Fibreglass PTFE + Fibra vidrio	R PTFE + Fibreglass PTFE + Fibra vidrio	V Vitor® (FKM)	N Nitrile Nitrilo
E Standard stem ext. Alarga. standard	2 F-1	2 GG25 / 1.4308	S PTFE + Carb. + Graphite PTFE + Carb. + Grafito	S PTFE+Carb. + Graphite PTFE+Carb. + Grafito	S PTFE+Carb. + Graphite PTFE+Carb. + Grafito		
F Security extension Alarga. seguridad	3 300 Lbs	3 1.0619 / 1.4027	X PTFE + Stainless steel PTFE + Acero inoxidable	G Graphite Grafito	G Graphite Grafito		
G Guided ball Bola guiada	4 Special Especial	4 WCC / CF8M 1.0619 / 1.4408	P PEEK®	U UHMWPE®	U UHMWPE®		
H Heating jacket Cámara calefacción	5 Tank bottom Fondo de cuba	5	K KELF®				
I Inclined stem Eje inclinado	6 600 Lbs	6 CF8M / CF8M 1.4408 / 1.4408	N Nylon®				
K Three pieces Tres piezas	7 4 way / 4 vias	7 1.4539 / 1.4539	D DELRIN®				
L Locking device Tope candado	8 3 way / 3 vias	8 Bronze / 1.4408	U UHMWPE®				
M Metal seat Asiento metálico	9 Wafer	9 LCC / CF8M 1.0619QT / 1.4408	C Cr-Carbide Metal				
O Degreasee Desengrasada			N Nitriding steel Acero nitrurado				
S Spring seat Asiento muelle							
T Simple stem extension Alargamiento simple							
U Unidirectional Unidireccional							
W Welded body Cuerpo soldado							
RB Reduced bore Paso reducido							

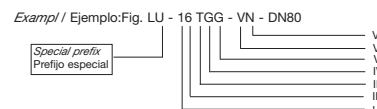



JULIO 98 REV. 3/06

Pekos Valves S.A.

C/ Rec del Molinar, 9 - Poligono Ind. El Circuit
08160 Montmeló - Barcelona (Spain)

Tel. : (+34) 93 579 93 70
Fax : (+34) 93 579 92 44

valvulas@pekos.es
www. pekos.es

