

## Data sheet

# Flow-compensated temperature controller AVTQ DN 15

### Description



AVTQ prevents high temperatures in the heat exchanger when no hot water is tapped by rapidly shutting off the heat supply (e.g. hot district heating water). AVTQ can be used with most plate heat exchangers. However, the heat exchanger manufacturer should be contacted to ensure that the chosen heat exchanger has been approved for use with the AVTQ.

- Pressure-controlled opening/closing on start/stop tapping.
- Infinite adjustment of operating temperature.

AVTQ controller consist of a thermostatic actuator, diaphragm element, main valve and pilot valve. Thermostatic actuator with diaphragm element and main valve are installed on the district heating (primary) side. The diaphragm element is, via impulse tubes, connected to the pilot valve on the domestic hot water (secondary) side.

#### Main data:

- DN 15
- $k_{vs}$  1.6
- PN 16 - Main valve
- PN10 - Diaphragm element and pilot valve
- Suitable for domestic hot water (DHW) production in range of 45 ... 60 °C
- Permanent no-load (idle) temperature (approx. 40 °C)
- Temperature (primary):
  - Circulation water / glycolic water up to 30%: 2 ... 100 °C
- Connections:
  - Ext. thread (weld-on and thread tailpieces)
- Return mounting

AVTQ is a self-acting flow-compensated temperature controller primarily for use in district heating systems with plate heat exchangers for instantaneous hot water production. It closes on rising sensor temperature.

It has permanent no-load (idle) temperature setting on about 40 °C which is offset by a pilot valve using flow-compensation principle during tapping. Tapping temperature can be set individually.

### Ordering

Example:  
Flow-compensated temperature controller, DN 15,  $k_{vs}$  1.6, PN 16, setting range 45 ... 60 °C,  $t_{max}$  100 °C, ext. thread

- 1x AVTQ controller, 45 ... 60 °C  
Code No: **003L7015**

#### Option:

- 1x Weld-on tailpieces  
Code No: **003H6908**

### AVTQ controller

Picture	DN (mm)	$k_{vs}$ (m <sup>3</sup> /h)	Connection		Code No.*
			Main valve ISO 228/1	Pilot valve ISO 228/1	
	15	1.6	G 3/4 A	G 1 A (DN 20)	<b>003L7015</b>

\* Controller incl. gland and compression fittings for mounting on  $\varnothing 6 \times 0.8$  mm copper impulse tube.

### Accessories

Picture	Type designation	DN	Connection	Code No.
	Weld-on tailpieces	15	-	<b>003H6908</b>
	External thread tailpieces		Conical ext. thread acc. to EN 10226-1	R 1/2"

**Ordering (continuous)**
**Service kits**

Picture	Type designation	Code No.
	Gasket for diaphragm housing	003L3154
	Thermostatic actuator incl. sensor stuffing box	003L7100
	Compression fittings for Ø6 mm copper tube (4 ferrules and 4 nuts)	003L7101
	Pilot valve excl. compression fittings	003L7108
	Main valve incl. complete valve insert	003L7109
	Diaphragm element excl. compression fittings	003L7111
	Sensor stuffing box incl. gasket	003L7120

**Technical data**

<b>Nominal diameter</b>	<b>DN</b>	<b>15</b>
$k_{VS}$ value	m <sup>3</sup> /h	1.6
Control ratio		100 : 1
Cavitation factor z		≥ 0.6
Leakage acc. to standard IEC 534		< 0.05 % <sup>4)</sup>
Nominal pressure	PN	16 <sup>1)</sup> 10 <sup>2)</sup>
Max. differential pressure	bar	6
Max. closing pressure		12
Medium		Circulation water / glycolic water up to 30% <sup>1)</sup> Domestic hot water (chlorine (cl) content max. 200 ppm) <sup>2)</sup>
Medium pH		Min. 7, max. 10 <sup>1), 2), 3)</sup>
Medium temperature	°C	2 ... 100 <sup>1)</sup> 2 ... 90 <sup>2)</sup>
Connections	valve	Ext. thread
	tailpieces	Weld-on and external thread
Setting range Xs	°C	45 ... 60
Time constant T acc. to EN 14597	s	4
Max. adm. temperature at sensor	°C	130
Max. water velocity around the sensor	m/s	1.5
Capillary tube length	m	1

**Materials**

Temperature controller	Valve body	RG5, DIN 1705, W.no. 2.1096.01
	Valve insert and valve cone	Dezincification resistant brass BS 2874
	Valve seat, pressure relief cylinder	CrNi steel, DIN 17440, W.no. 1.4404
	Valve spindle	CrNi steel, DIN 17440, W.no. 1.4435
	Valve plate, O-ring, diaphragm	EPDM
	Diaphragm housing	CrNi steel, DIN 17440, W.no. 1.4435
	Diaphragm plate	CrNi steel, DIN 17440, W.no. 1.4436
	Diaphragm spindle	Dezincification resistant brass BS 2874
Diaphragm housing stuffing box	Housing	Dezincification resistant brass BS 2874
	Spindle	CrNi steel, DIN 17440, W.no. 1.4401
Sensor	Sensor	Copper
	Sensor stuffing box	Dezincification resistant brass BS 2874
	Gasket	EPDM
	Charge	Carbon dioxide (CO <sub>2</sub> )
Pilot valve	Valve body	Dezincification resistant brass BS 2872
	Valve base	Dezincification resistant brass BS 2874
	Valve spindle	CrNi steel, DIN 17440, W.no. 1.4401
	Setting spring	CrNi steel, DIN 17440, W.no. 1.4568
	Cone, spring retainer	PPS-plastic
	O-ring	EPDM

<sup>1)</sup> Valid for primary side (main valve)

<sup>2)</sup> Valid for secondary side (pilot valve and diaphragm element)

<sup>3)</sup> In case of domestic hot water (secondary side) pH lower than 7 -> the hardness of the water must be larger than the sulphate element

$$\frac{\text{HCO}_3^-}{\text{SO}_4^{--}} \geq 1$$
<sup>4)</sup> at T idle nom. + 10 °C

**Application principle**

The controller AVTQ must be installed in the return pipeline only.

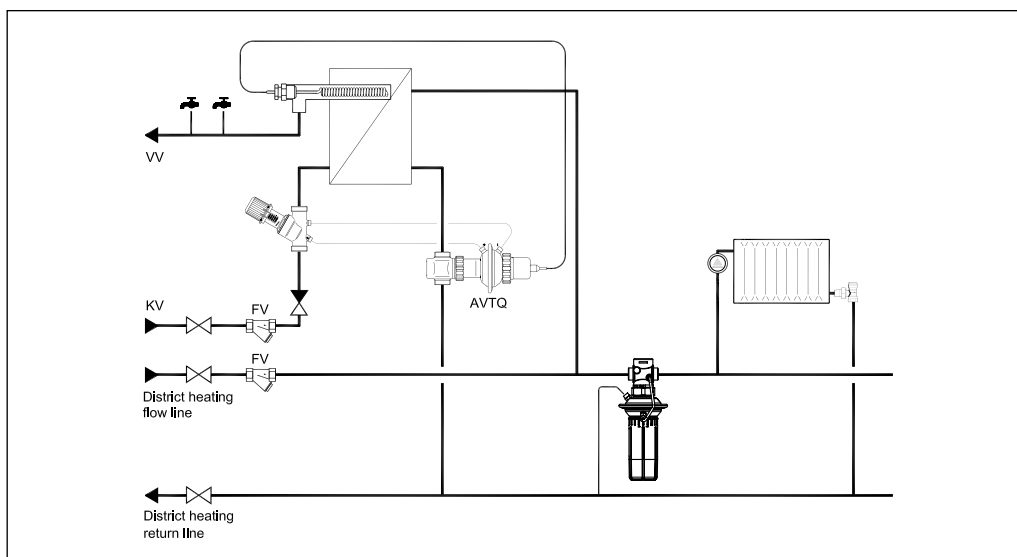

When domestic hot water (DHW) is tapped, flow through the pilot valve creates a pressure drop (force in the diaphragm housing) which is used to increase the temperature level from no-load (idle) to set tapping temperature.

This temperature increase causes the main valve to open for flow on the district heating side and close when the temperature level again falls to the no-load operating level. No-load operation prevents the district heating line becoming cold. Tapping temperature can be set individually.

**Design**

1. Thermostatic actuator with sensor stuffing box
2. Pressure spindle
3. Diaphragm housing stuffing box
4. Nut
5. Diaphragm housing
6. Diaphragm spindle
7. Control diaphragm
8. Compression connection for impulse tube
9. Intermediate ring
10. Nameplate
11. Main spring
12. Damping + teflon ring
13. Valve spindle
14. Valve insert
15. Pressure relief cylinder
16. Valve body (main valve)
17. Handle for temperature setting
18. Spindle
19. Valve base
20. Spring retainer
21. Setting spring
22. Pressure equalizing hole
23. Valve cone
24. Valve body (pilot valve)
25. Compression connection for impulse tube
26. Sealing bolt of sensor stuffing box
27. Gasket of sensor stuffing box
28. Housing of sensor stuffing box

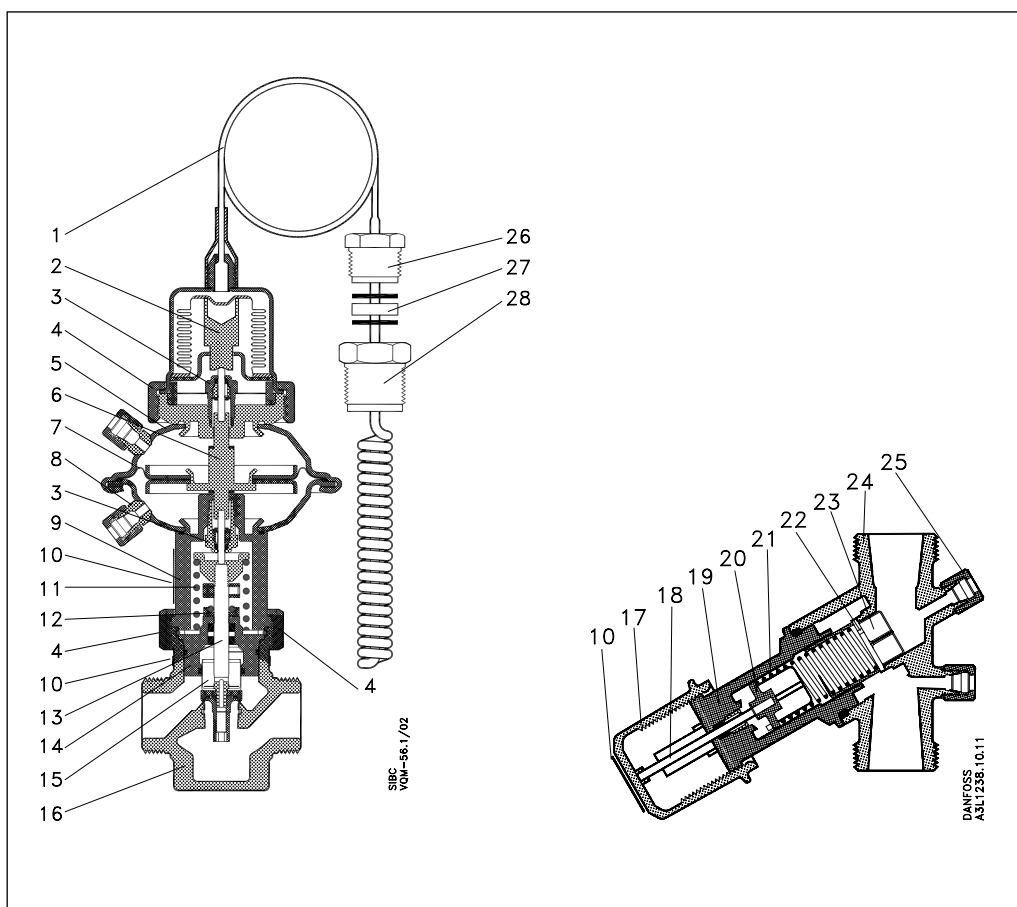

Installation

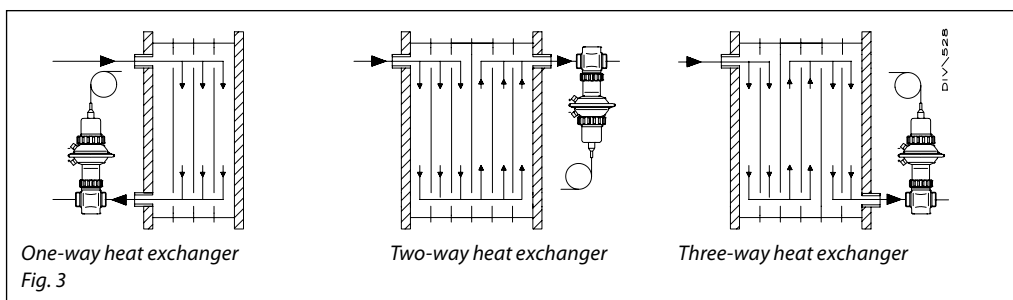

AVTQ can be used with most types of plate heat exchangers.

The AVTQ manufacturer should be contacted to ensure:

- that the AVTQ is approved for use with the chosen heat exchanger
- the correct material selection when connection the heat exchangers
- the correct connection of one pass plate heat exchangers; layer distribution might occur, i.e. reduced comfort

The system functions optimal when the sensor is installed right inside the heat exchanger (see page 3). However, the sensor head should be placed approx. 5 mm from the plate which divides the primary and the secondary side of the exchanger. If the sensor head is placed too close to the dividing plate, the sensor might measure the temperature of the plate and not the temperature of the medium. For correct no-load operation, thermal flow should be avoided since hot water rises and increases the no-load consumption.

*Note: water velocity around the sensor must be in accordance with the requirements for copper tube.*

The temperature controller (main valve):

- must be installed in the return pipeline on the district heating (primary) side of the heat exchanger
- the diaphragm element can be turned in any position in relation to the valve body so that impulse tube can be connected in the required direction

The pilot valve:

- must only be installed in the flow pipeline on the secondary side of the heat exchanger
- in systems where it cannot be excluded that drinking water is contaminated with fine dust from time to time, it is recommended not to mount the pilot valve with the impulse tube connections downwards (fig.2) to avoid dirt ingress in the impulse tubes and diaphragm housing

The sensor can be installed in any position (fig.1)

It is strongly recommended that:

- the primary and secondary sides of the heat exchanger should be flushed through before the heating system is used the first time. In addition the (+) and (-) side of the diaphragm should be vented.
- dirt strainers with a mesh size of max. 0.6mm should be installed in both, the cold tap water pipeline ahead of the pilot valve and in the flow pipeline from the district heating network.

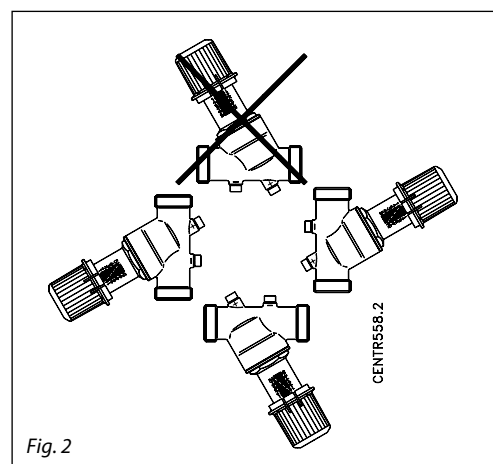
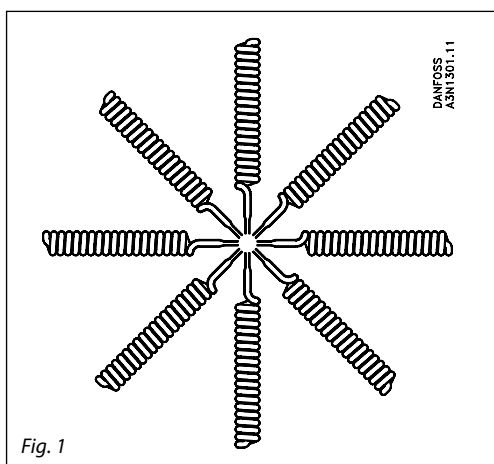

Sizing

Example

Given data:

$$T_1 = 65 \text{ }^\circ\text{C}$$

$$T_3 = 50 \text{ }^\circ\text{C}$$

$$T_4 = 10 \text{ }^\circ\text{C}$$

$$Q_2 = 0.3, 0.6, 0.9 \text{ m}^3/\text{h} \text{ (300, 600, 900 l/h)}$$

$T_1$  - District heating water flow temperature

$T_3$  - Hot water temperature

$T_4$  - Cold water temperature

$Q_2$  - Hot water service flow

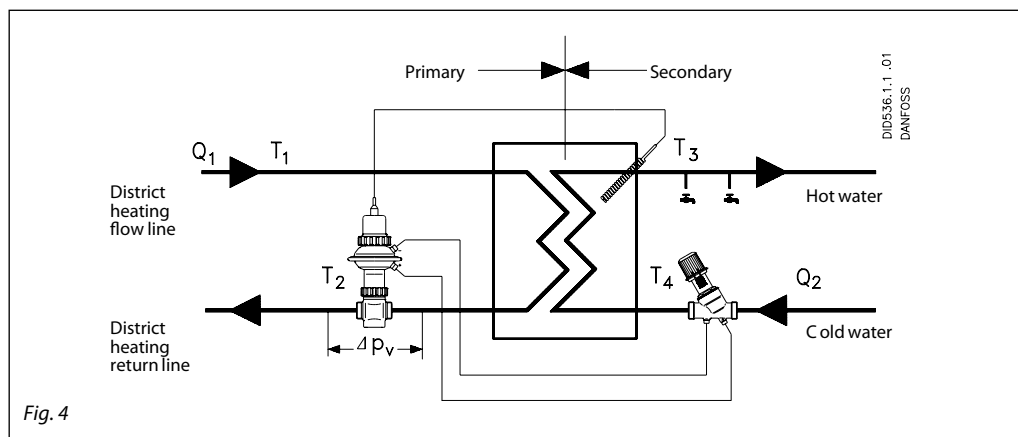

Fig. 4

The maximum heating power  $P_{max}$  is calculated according to formula:

$$p_{max} = \frac{Q_2 \times \Delta T_2}{0.86} = \frac{Q_2 \times (T_3 - T_4)}{0.86}$$

$$p_{max} = \frac{900 \times (50 - 10)}{0.86} = 42 \text{ kW}$$

Based on max. heating power heat exchanger could be selected. Information about the cooling across the primary side of heat exchanger can be acquired either by contacting the manufacturer of the heat exchanger or by using the manufacturer's dimensioning diagram.

In the example chosen cooling on primary side ( $\Delta T_1$ ) is 43 °C, 40 °C or 39 °C, the differential pressure across the AVTQ main valve ( $\Delta p_v$ ) is 0.5 bar.

The primary flow  $Q_1$  can be calculated according to formula:

$$Q_1 = \frac{P_{max} \times 0.86}{\Delta T_1} = \frac{42 \times 0.86}{39}$$

$$Q_1 = 925 \text{ l/h}$$

Using the above data, the needed capacity of the main valve ( $k_v$ ) can be calculated:

$$k_v = \frac{Q_1 [\text{m}^3/\text{h}]}{\sqrt{\Delta p_v [\text{bar}]}} = \frac{0.925}{\sqrt{0.5}}$$

$$k_v = 1.31 \text{ m}^3/\text{h}$$

Chosen AVTQ main valve has  $k_{vs}$  1.6  $\text{m}^3/\text{h}$  and therefore is big enough. Values for flows of 300 and 600 l/h are calculated on the same way and entered in the table.

Tab.1

W (kW)	Secondary flow $Q_2$ (l/h)	Primary flow $Q_1$ (l/h)	$k_v$ ( $\text{m}^3/\text{h}$ )	Cooling $\Delta T_1$ ( $^\circ\text{C}$ )
14	300	280	0.39	43
28	600	600	0.85	40
42	900	925	1.31	39

Sizing (continuous)

The pressure drop across the pilot valve can be read from the diagram below

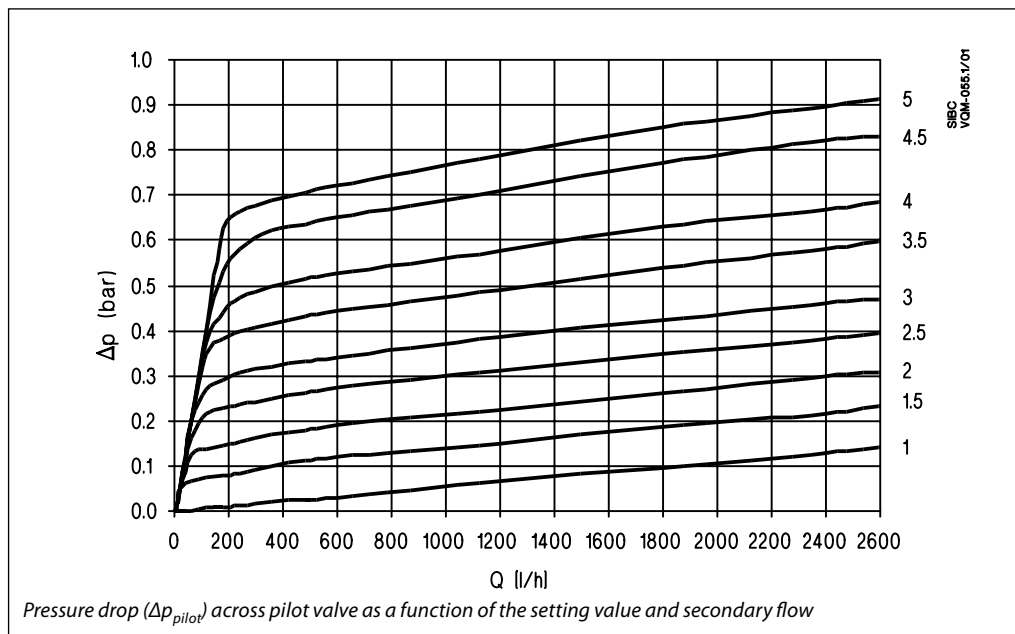

**Setting**

The AVTQ controller can be used with plate heat exchangers of up to 75 kW. As a result of the flow compensation principle an actual dimensioning of the valve is unnecessary, because the valve will always adjust around the required temperature without regard to the flow.

This means that if the controller is set to 50 °C (this is done at 75% of max. tapping flow to obtain optimum control), then this temperature will be maintained whether or not the actual flow is 120 l/h, 900 l/h or more. Between 120 l/h and 900 l/h the temperature will vary approx. 4 °C.

**Typical settings:**
*Minimum:*

Designation	Application values	Pilot valve setting
Flow temperature, primary	$T_p = 65\text{ °C}$	3.0
Differential pressure across the AVTQ main valve	$\Delta p = 0.5\text{ bar}$	
Hot water temperature, secondary	$T_s (\text{hot}) = 50\text{ °C}$	
Cold water temperature, secondary	$T_s (\text{cold}) = 10\text{ °C}$	
Secondary flow	$Q_s = 750\text{ l/h}$	

*Maximum:*

Designation	Application values	Pilot valve setting
Flow temperature, primary	$T_p = 100\text{ °C}$	2.0
Differential pressure across the AVTQ main valve	$\Delta p = 6.0\text{ bar}$	
Hot water temperature, secondary	$T_s (\text{hot}) = 50\text{ °C}$	
Cold water temperature, secondary	$T_s (\text{cold}) = 10\text{ °C}$	
Secondary flow	$Q_s = 750\text{ l/h}$	

The values mentioned above are reference values and therefore corrections of pilot valve settings might be necessary in order to obtain the required temperature.

*Other approx. setting values:*

Tapping temperature = 50 °C  
 Tapping flow = 750 l/h

$T_{\text{primary}}$	$\Delta p$ (bar)			
	0.5	1.0	3.0	6.0
65 °C	3.0	2.5	2.5	2.5
80 °C	2.75	2.5	2.25	2.25
100 °C	2.5	2.5	2.25	2.0

Dimensions

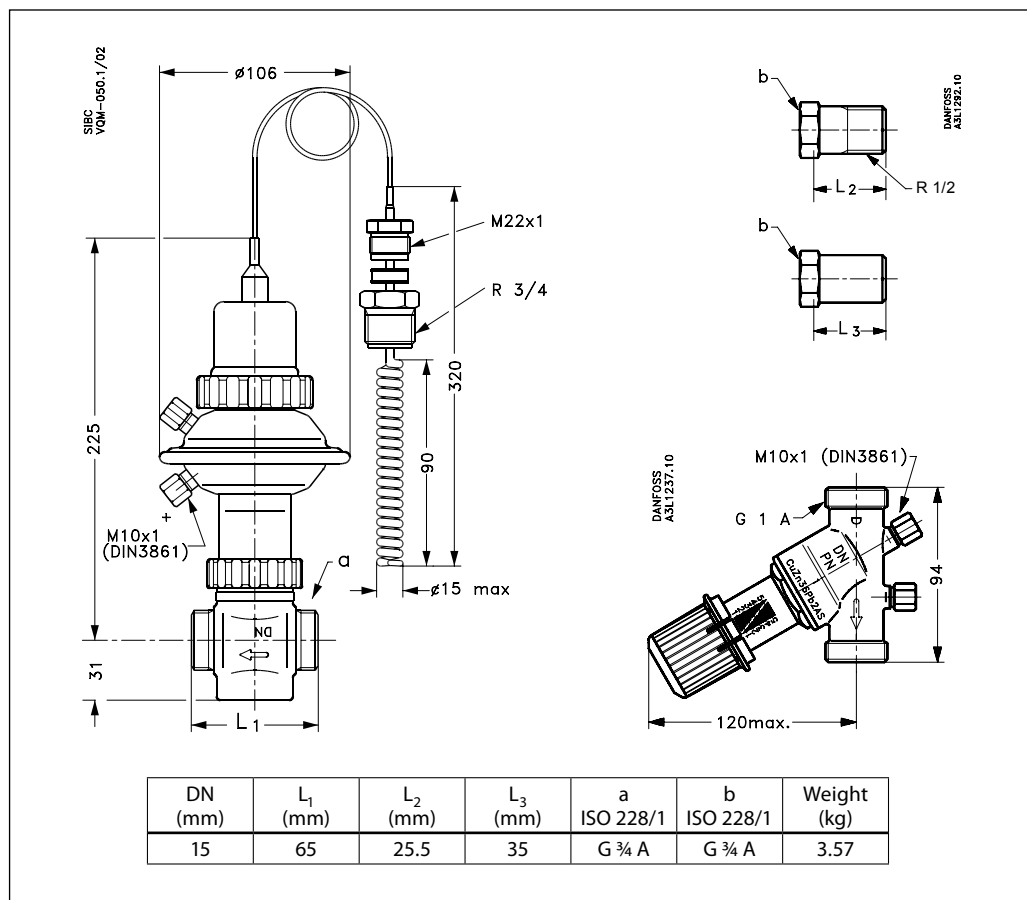

Danfoss can accept no responsibility for possible errors in catalogues, brochures and other printed material. Danfoss reserves the right to alter its products without notice. This also applies to products already on order provided that such alterations can be made without consequential changes being necessary in specifications already agreed. All trademarks in this material are property of the respective companies. Danfoss and the Danfoss logotype are trademarks of Danfoss A/S. All rights reserved.